

PRESSURE SWITCH



Dedicated Sales Rep for Your Area



97% Fill Rate



Shipping within 24 Hours



State of the Art Warehouse System



Technical Support



Quality Control Program

25 Whaley Avenue
Milverton, Ontario N0K 1M0
Toll Free 1-800-561-3164
Phone: (519) 595-4444
Fax: (519) 595-4380
www.boshart.com



Standard water pump switch designed for the control of electrically driven water pumps of all types.

- High Endurance and Quality
- Easy To Install
- Adjustable Pressure Setting
- Available in 3 Factory Settings: 20-40 PSI; 30-50 PSI; 40-60 PSI
- Universal Fit For Most Domestic Water Pumps
- Low Level Cut-Out Safety Feature
- Individually Boxed

Order Information

Part Number	Barcode 777808+	Pressure Setting (PSI)		Connection	Description	Quantity	
		Cut In	Cut Out			Carton	Case
PS02-2040	310005	20	40	1/4" FPT	Standard Duty Switch	1	20
PS02-3050	310012	30	50	1/4" FPT	Standard Duty Switch	1	20
PS02-4060	310029	40	60	1/4" FPT	Standard Duty Switch	1	20
PS02LP-2040	310067	20	40	1/4" FPT	Low Pressure Cut Off Switch	1	20
PS02LP-3050	310074	30	50	1/4" FPT	Low Pressure Cut Off Switch	1	20
PS02LP-4060	310081	40	60	1/4" FPT	Low Pressure Cut Off Switch	1	20



Distributed By:

Installation & Setting

WARNING! Serious electrical shock could result if power is not turned off, and remains off until servicing is complete.

1. Turn off power and drain system.
2. Disconnect wires and remove defective switch from system.
3. Install new pressure switch. NOTE: Replace any fittings that are old and corroded.
4. Permanently connect with approved cable and connectors.
5. With **POWER OFF**, adjust switch to desired pressure using instructions on the inside of the switch cover.
6. Turn on power and start system by following the **Start-up & Reset Procedures** inside the cover.

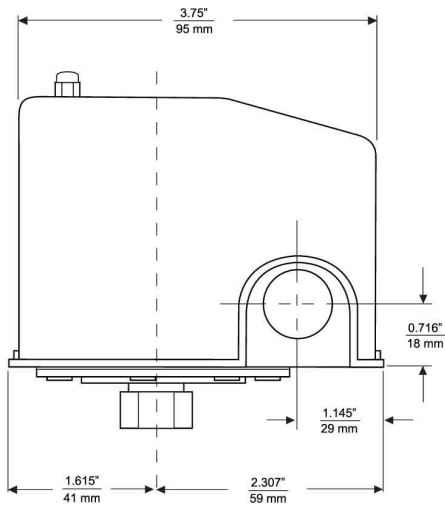

Electrical Ratings 2- Pole HP Ratings

Volts	Single Phase	Amperage
115	1.5 HP	20
230	2.0 HP	12

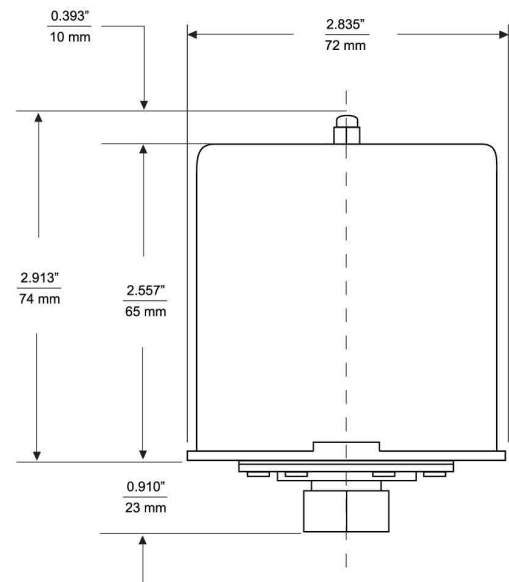

Specifications

Models PS02, PS02LP

Diaphragm Actuated
 Standard Action - Contacts open on pressure rise
 Environmental Rating Enclosure - Type 1 Indoor Use

Pressure Ranges:

Cut-In range 10-45 PSI
 Cut-Out Range 20-60 PSI
 Approximate Differential 15-30 PSI

Switches can be field adjusted to any desired range, however, they must fall within the 3 parameters stated above.

Temperature:

Ambient: -30°C (-22°F) to 70°C (158°F)
 Media: -30°C (-22°F) to 125°C (257°F)

Application Information

Auto Low-Pressure Cut-Off (PS02LP Model)

When pressure drops 11 PSI below the Cut In, or On rate, the switch automatically shuts off. Manual restart is necessary.

When using a pre-charged tank, ensure that the tank pre-charge is 3-5 PSI less than the cut-in pressure of switch, to eliminate nuisance tripping.

1/4" tube fitting for jet pump use included with low pressure cut-off pressure switch.

Start-Up & Reset Procedure:

Hold lever in START position until system pressure builds to within 10 PSI, or less, of the start pressure. (There will be no resistance on the lever by this point.)